

WattsOn®-Mark II Installation Quick Reference Guide

*This guide shall serve as a brief installation overview.
Full instructions should be reviewed in the WattsOn-Mark II User Manual*



DANGER

Line voltages up to 600 VRMS may be present on the input terminals of the device and throughout the connected line circuits during normal operation. These voltages may cause severe injury or death.

Installation and servicing must be performed only by qualified, properly trained personnel.

Hardware Installation Checklist

- Install meter on DIN Rail or back plate in a secure, dry location.
- Wire 12-35V VDC (or 24VAC) Power Supply to "Power" Terminal.
- Configure Modbus Address via Rotary Switch (N/A for Ethernet models)
- Connect Outputs (relays / RS-485 / Ethernet) to desired peripherals
- Connect Current Transformers to CT inputs (see "CT wiring")
- Wire Line Voltage(s) to relevant Voltage Inputs (wire protection required)
- Open any external CT shorting blocks (5A meters)

Commissioning Checklist

- Enter CT Ratios (see "CT Ratios" section)
- Enter PT Ratios (if applicable)
- Observe Voltage & Current LEDs showing presence of phase signals and their status (see Current LED table below)
- Verify Voltage & Current Readings (either using on-board display, or remote monitoring system)
- Note Power Factor Readings. Readings below ± 0.700 usually indicate improperly wired CTs (voltage to current mismatch)

CT Ratios

For mA CTs, the ratios are listed in the table. These generic values may be used, however all Elkor mA CTs are labelled with a factory measured turns ratio and phase compensation, which may be applied per each phase if ultimate accuracy is desired.

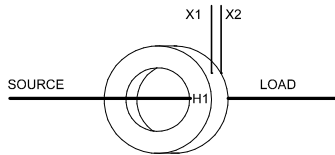

Typical CT Label



mA CTs	Ratio
MCTA	2500:1
MCTB	4000:1
MS160	3000:1
MS240, MS360	2000:1
MSCT1, 2, 3	7500:1
MSCT5	10500:1
MRS-75, 125, 2x3	7500:1
MRS-3x5	10000:1

5A CTs	Ratio
nnn : 5A	nnn:5

Rogowski Coil	Ratio
RC-600 (60 Hz)	1000:120
RC-600 (50 Hz)	1000:100

Current LEDs	Description
	Current Present, Positive kW (Import)
	Current Present, Negative kW (Export)
	Current Present, Positive kW, kVAR > kW (likely bad CT-to-voltage match)
	Current Present, Negative kW, kVAR > kW (likely bad CT-to-voltage match)
	LED off if current is < 0.1% of the full scale input.

Status LED	Description
	Normal Operation
	Bootloader Mode (DIP switch "0"?)
	Force RS-485 parameters (DIP "0" after power-up)
	Bootloader mode (DIP "0" or firmware corrupt)
	Product malfunction, contact factory

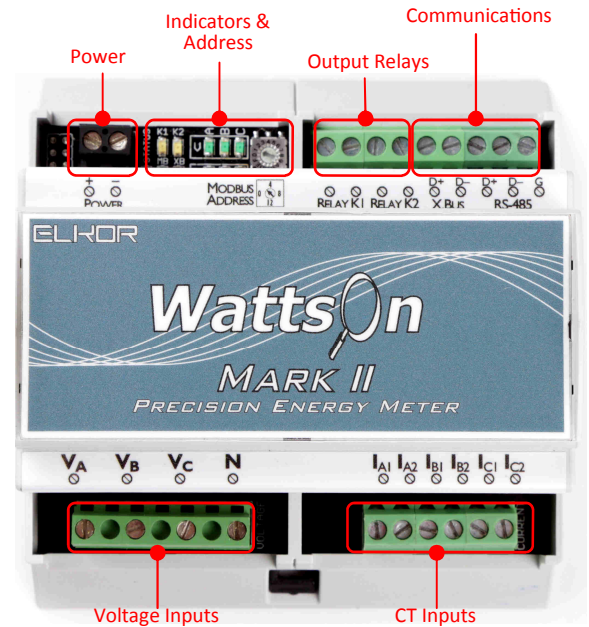

Typical Wiring Configurations

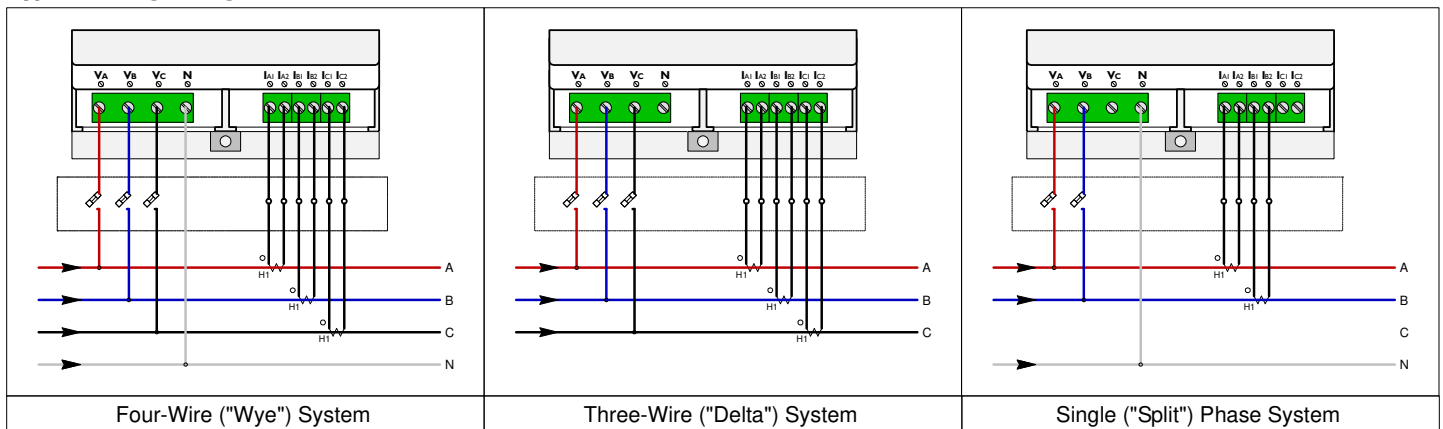

SPECIFICATIONS

INPUTS				
Power Supply	12-30 VDC or 24 VAC, < 2VA			
Supported Wiring Types	Up to 347/600V Delta, Wye Single-phase installations up to 347V RMS Split-phase (two phase) installations			
Frequency	40-70 Hz nominal (30-300 Hz max)			
Voltage	20Vac - 347Vac L-N (600Vac L-L),(450Vac L-N, 780V L-L absolute max.) Input Impedance: 1.5M Ω (line-to-neutral) minimum, 3.0M Ω (line-to-line) minimum			
Current	<i>-5A Model</i>	<i>-mA Model</i>	<i>-mV Model</i>	<i>-RC Model</i>
Input Rating	5A nominal (10A max)	Up to 200mA CTs (ie: Elkor mA output CTs)	333mV (400mV max)	Up to 360mV via Rogowski Coils
Input Impedance	0.05 Ω max	1.5 Ω typ.	800k Ω min, 1.2M Ω typ.	600k Ω min.
Wire Size	Voltage: AWG 30-12, (AWG 16-22 recommended) Current: AWG 24-12, (AWG 12-16 recommended for 5A CTs)			
Overload	20% continuous (voltage & current) maintaining full accuracy. 100% momentary current overload.			
Tightening Torque	7.0 Lb-In (Voltage), 4.4 Lb-In (Other)			

OUTPUTS	
Modbus/RTU	RS-485 2-wire, 9600 to 230400 baud (-M1 Models)
BACnet MS/TP	RS-485 2-wire, 9600 to 115200 baud (-M2 Models)
Expansion Bus	RS-485 2-wire, for accessory expansion
Relay	Two Solid-State Relay Outputs (100 mA @ 50V max). Normally Open (N.O.) User Programmable for alarm, status or pulse output
Indicators	LED indication of: Voltage, Current, Power, Output relay state, Status, Communication
Display (Option)	Back-lit Graphic LCD Display 128x32 (-DL models only)
Ethernet (Option)	ETnet module (integrated) featuring Modbus/TCP, Webserver, HTTP POST, SSL
BACnet/IP (Option)	ETBAC module (integrated) featuring BACnet/IP connectivity
Datalogging (-DL model)	2MB on-board flash with battery backed RTC. Configurable to log any metering parameter

ACCURACY		
Standards	ANSI C12.20 Class 0.2 Accuracy Certified by 3rd party NRTL Supports EN 50470-1, EN 50470-3, IEC 62053-21, IEC 62053-22, and IEC 62053-23 standards.	
Current (A)	0.05% typ	0.1% max
Voltage, L-N (V)	0.1% typ	0.2% max
Voltage, L-L (V)	0.2% typ	0.3% max
Power (W, VA, VAR)	0.1% typ	0.2% max
Energy	0.1% typ	0.2% max
Power Factor	0.2% max	
Frequency	0.01% max	
Input Bandwidth	2 kHz (33rd Harmonic @ 60Hz, 40th Harmonic @ 50Hz)	
Data Update Frequency	10Hz (every 100ms) for instantaneous W, VA, VAR 2Hz (every 500ms) for all other parameters	

MECHANICAL	
Dimensions	4.2" x 4.3" x 2.4" W x L x H
Mass	0.15 kg (-mA and -mV models) 0.23 kg (-5A-DL model)
Mounting	DIN Rail Mount or 3-point screw wall mount

ENVIRONMENTAL (Protected Installation)	
Operating Temperature	-40°C to +70°C
Storage Temperature	-40°C to +70°C
Humidity	10 to 90% non-condensing

COMPLIANCE	
Safety	UL Listed (#E250395)
Isolation	3,500VAC (min) input-to-output
Electromagnetic Emissions	FCC part 15 Class B