

ELKOR MOC1 - TRUE RMS 3 PHASE POWER TRANSDUCER

The ELKOR MOC1 is a cost effective, true RMS three phase power transducer that provides pulses proportional to energy consumption (Wh) and two Analog Output signals; one is proportional to the instantaneous value of real power (Watts) while the other may be set to represent either VA, Averaged Current, Averaged Voltage or Power Factor.

FEATURES

- ◆ Accurate, true RMS measurements at low cost.
- ◆ EMS compatible output signals:
 - slow pulses for kWh
 - 0-5VDC (4-20mA optional) for kW and either kVA, Iabc, Vabc or PF.
- ◆ Direct connection up to 600VAC with supplied approved isolating transformers.
- ◆ Standard 5A CTs or small MCT current sensors that may eliminate the need for CTs.
- ◆ Ideal for Low Voltage installations.
- ◆ RS485 communication available.

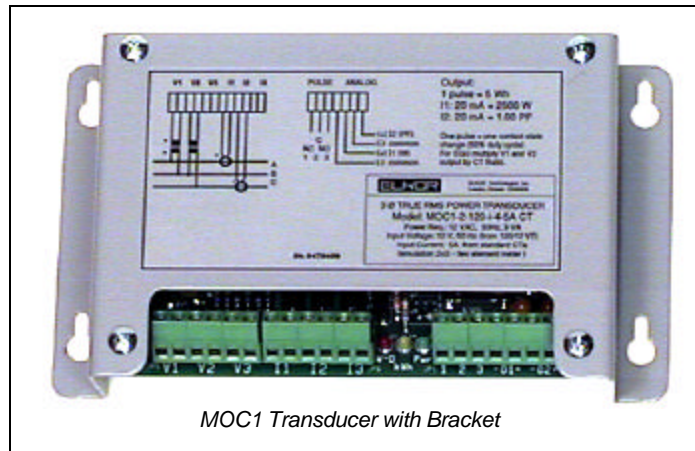

MOC1 Transducer with Bracket



Voltage Transformer (VT)



MCT Current Sensors

PRODUCT DESCRIPTION

The MOC1 true RMS 3 phase transducer is a micro-processor based metering product that provides a cost effective and practical method for electrical load monitoring. It is designed for industrial and commercial applications as a sensor for the Energy Management system, or as a stand alone transducer.

The MOC1 is supplied with small interfacing voltage transformers, which act as low voltage PTs, for direct connection to any electrical system (Delta or Wye) up to 600 VAC. The first PT also provides 14 VAC power supply for the unit. The MOC1 may be installed with only one voltage transformer, connected between two phases, for systems with reasonably balanced voltages. The transducer accepts standard 5A current transformers (CTs) or small current sensors (MCTs) that may be applied on 5A secondary wires of the existing CTs. This allows the MOC1-MCT unit to be connected to the existing metering current transformers without any interference. Other types of the mV output 'safe' CTs, including split core units, are also supported by this transducer.

The MOC1 features LED indication for improper input wiring (phase rotation, reversed CTs etc.) but its readings are not effected by reversed inputs polarity. For energy consumption (Watt-hours) the MOC1 provides one SPDT (Form C) dry contact with slow 50% duty cycle pulses or one standard 100 ms pulse output (for totalizers etc.). In addition, two 0-5 VDC analog signals are available (4-20 mA is optional). One of these AO signals is always proportional to instantaneous real power (Watts) while the other can be set to represent either VA, Iabc, Vabc or PF. RS485 based digital communication is also available.

The MOC1 may be supplied as an OEM product (PC board with stand-offs), with an open type mounting bracket (as shown on photo), or mounted in a 20 Ga. steel chassis box. The transducer may be installed with other low voltage equipment such as EMS hardware etc., with its interfacing transformers located remotely in the electrical enclosure or the switch gear. A counter-totalizer may be easily added to the unit.

ELKOR MOC1 - TRUE RMS 3 PHASE POWER TRANSDUCER

SPECIFICATIONS

INPUT:

Voltage: 600/347VRMS
480/277VRMS
230/127VRMS
208/120VRMS
240/120 (Split Phase)

Approved isolating transformer(s), will be provided with the MOC1.

In most applications only one transformer is sufficient (please refer to ordering inf.).

Current: 5A from standard CTs (MOC1-CT);

MCTs 5A primary (MOC1-MCT)

Max. Ratings: Voltage - 700 VRMS

OUTPUT SIGNALS:

Pulse - reed relay, SPDT contact, 500mA maximum @24V, proportional to energy consumption (Wh), Max.0.1 Hz, 50% duty cycle or 100 ms pulse (opto -open collector)
Analog - two 0-5VDC (4-20mA) signals; one proportional to instantaneous Watts, second to either specified parameter: kVA, Averaged Current, Averaged Voltage or PF.

POWER SUPPLY REQUIREMENTS:

3 VA/12VAC - the 'on board' power supply uses 12VAC input supplied by the voltage isolating transformer (VT) provided with the board.

ACCURACY:

0.5% TRMS FS for current;
0.8% TRMS of full rated span for all other measured and calculated parameters (MOC1-3 and MOC1-2 @ rated frequency, PF1.0 to 0.7)

ENVIRONMENT:

Indoor; 0-50 C, 10-90%RH non-condensing.

WARRANTY:

Full two years manuf acturer's warranty.

Contact *ELKOR Technologies Inc.* for specification details.

INSTALLATION DETAILS

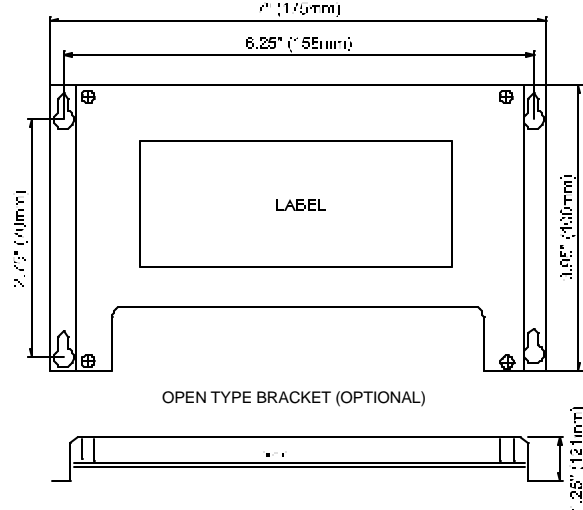
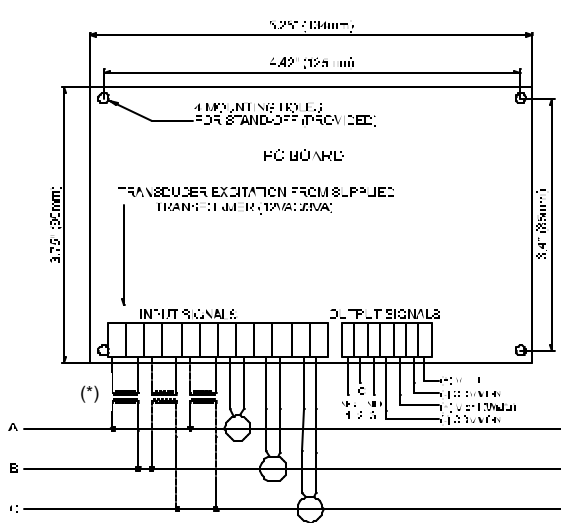

ORDERING INFORMATION

Number of Voltage Inputs (Isolating Transformers) Required:

1- One transformer
NOTE: (*) *In most applications the system voltage at the source is reasonably equal in all phases, even with the unbalanced load. The MOC1-1 can use only one transformer applied between two phases.*

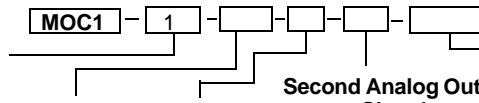

Nominal Voltage	AO Signal
600/347	V- 0-5VDC
480/277	I - 4-20mA (source)
440/250	Note:
230/127	0-10 VDC
208/120	is also available
240 Split	

Second Analog Output Signal :

- 1- proportional to Vabc
 - 2- proportional to VA
 - 3- proportional to Iabc (Averaged Current)
 - 4- proportional to PF
- The first AO is proportional to Watts.*

Current Input:

CT - 5A standard CT input (3 CTs are required for most systems)¹
MCT - mV Current Sensors; see MCT data sheet, split core also available

(¹) *ELKOR may supply standard 5A CTs and MCTs in most sizes, including split core units. Please ask for quotation specifying the CT ratio and the required window size.*

ELKOR Technologies Inc.
6 Bainard St., Unit 1
London, Ontario N6P 1A8, Canada

Distributed by: